

LEKTRO

1190 S.E. Flightline Drive, Warrenton, Oregon 97146-9692
1-800-535-8767 • 503-861-2288 • Fax 503-861-2283
E-mail: sales@lektro.com
http://www.lektro.com

Model AP8700C AIRCRAFT TOWING VEHICLE FOR AIRCRAFT UP TO 55,000 LBS/24,948 KG

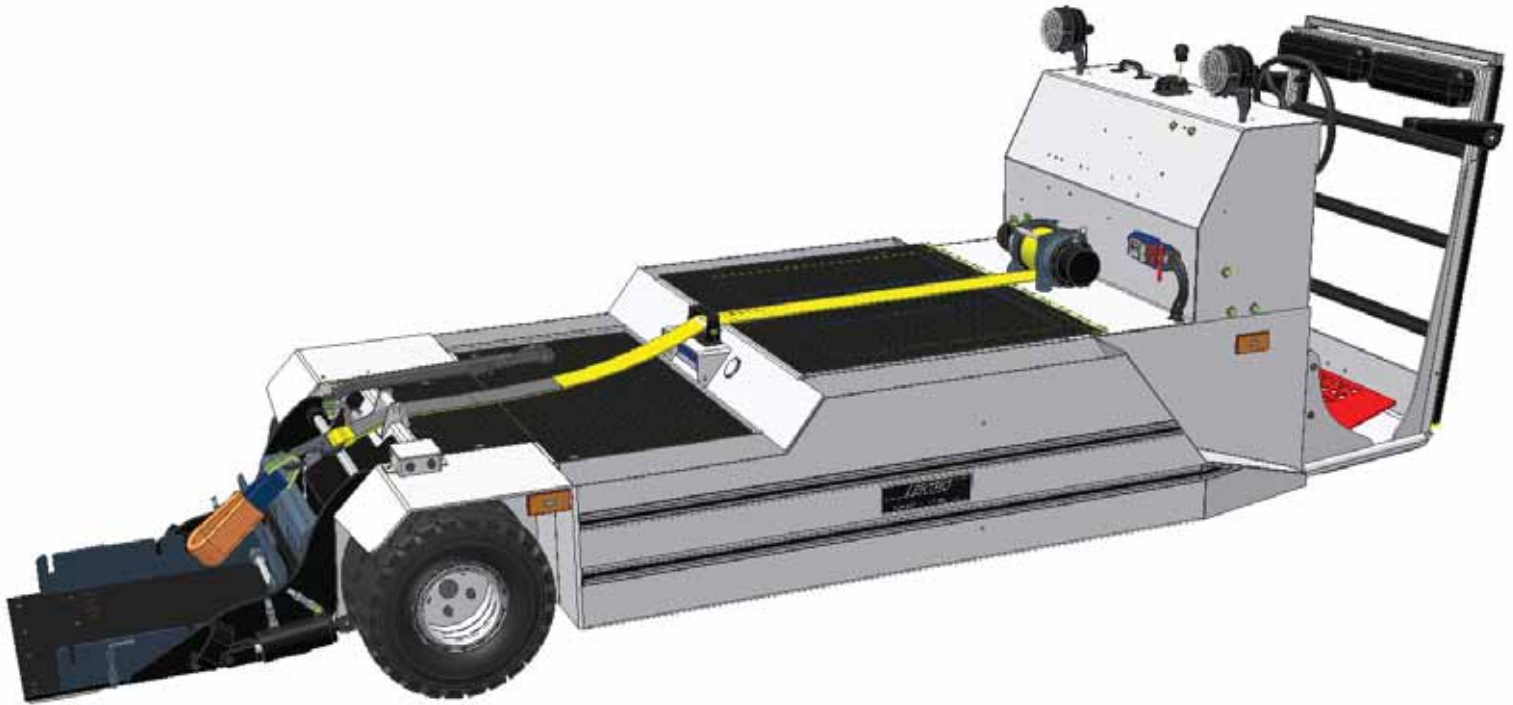

AP8700C FEATURES:

Vehicle Drive: Heavy-duty 9 inch frame, 48-volt D.C. Traction Motor coupled to a heavy-duty Dana 44 Differential. Limited Slip Differential, Optional.

Motor Speed Control: State of the art General Electric EV-100 LXT Electronic Speed Control with on-board trouble shooting diagnostics. Speed controlled by combination Hand Throttle/Directional Lever.

Batteries: Eight 6-volt, 350 ampere hour Batteries (20 hr. rate), wired in series. Additional Battery options available, (consult factory).

G.P.U.: Built-in 12/24/28 volt, 800 cold cranking ampere output capability, standard. 1175 cca, Optional. An independent 1175 cca battery and charging system is available.

Battery Charger: Fully automatic 50 ampere D.C., 220-volt A.C., 60 hz, Single Phase Charger, standard. 50 hz, Optional.

Nose Gear Lift Cradle: Lektro's patented Universal Nose Gear Lift Cradle is activated by an Electric/Hydraulic pump assembly with dual cylinders, and is capable of handling dual and single wheel aircraft as well as those with or without wheel fairings. A hold down provision for light-nosed aircraft is standard.

Winch: Heavy-duty Hydraulic Winch with automatic safety cut-off. Winch Strap and universal Strut Straps included.

Steering: Automotive-type wheel coupled to an automotive gear box resulting in very responsive steering action.

Service Brakes: Foot operated dual independent hydraulic disc-type Service Brakes at each drive wheel.

Parking Brake: Foot operated Automatic Deadman Parking Brake.

Front Drive Tires: Dual 5.00 x 8 10-ply Pneumatic Traction Drive Tires. Chains optional for slippery conditions. Poly-foam filled tires available.

Rear Steer Tires: Dual 5.00 x 8 8-ply Pneumatic Highway Steer Tires. Poly-foam filled tires available. Steer Axle Suspension, Optional.

Lighting: Single 360 degree Rotating Headlight. Dual Headlights, Optional. Four flashing amber Running Lights positioned around tug to illuminate sides.

Extension Ladder: Four-step Ladder attached to operator's back rest.
Operator's Compartment: Two person configuration, stand-up operation with restraint.

Construction: Welded steel plate polymers, protected by primer and industrial, high-gloss red urethane paint. A special protective Polyurethane coating is applied to all chassis components to prevent rust, scratches and corrosion. Custom colors are optional.

SPECIFICATIONS:

Length.....	159.25 in / 404.6 cm
Width	54.75 in / 139.2 cm
Height (at top of steering wheel).....	49.75 in / 126.1 cm
Turning Radius	139 in / 353 cm
Wheel Base	81.25 in / 206.5 cm
Vehicle Speed, Empty	7 m.p.h. / 11.2 kph
Vehicle Speed, Loaded (To Max. Vehicle Capacity)	3 m.p.h. / 4.8 kph
**Lift Cradle Capacity	5500 lbs / 2495 kg
Nose Gear Cradle Lifting Height.....	9 in / 23 cm
Ground Clearance	5 in / 12.7 cm
Chassis Weight w/o Batteries & Charger	2970 lbs / 1347 kg
Chassis Weight w/ Motive Batteries & Charger.....	4300 lbs / 1950 kg
Chassis Weight w/ Motive & GPU Batteries & Charger.....	4650 lbs / 2109 kg

**Lift Capacity is calculated with 18 in / 46 cm diameter aircraft tire in lift cradle. Aircraft tire center line at 20.5 in / 52 cm from drive tire center line.

ADDITIONAL OPTIONS:

Pintle Towing Hook, Specialized Aircraft Towing Adapters and Custom Highlift Adapters are available (consult factory). Illustration may show some optional equipment.

*LEKTRO reserves the right to make changes and improvements in products and specifications without notice or obligation.

PATENT Nos. 5,151,003/5,302,075. Other Patents Pending. 03/09

LEKTRO

1190 S.E. Flightline Drive, Warrenton, Oregon 97146-9692
1-800-535-8767 • 503-861-2288 • Fax 503-861-2283
E-mail: sales@lektro.com
http://www.lektro.com

Model AP8700C AIRCRAFT TOWING VEHICLE

FOR AIRCRAFT UP TO 55,000 LBS/24,948 KG

