

LEKTRO

1190 S.E. Flightline Drive, Warrenton, Oregon 97146-9692
 1-800-535-8767 • 503-861-2288 • Fax 503-861-2283
 E-mail: sales@lektro.com
 http://www.lektro.com

Model AP8600 AIRCRAFT TOWING VEHICLE FOR AIRCRAFT UP TO 28,000 LBS/12,700 KG

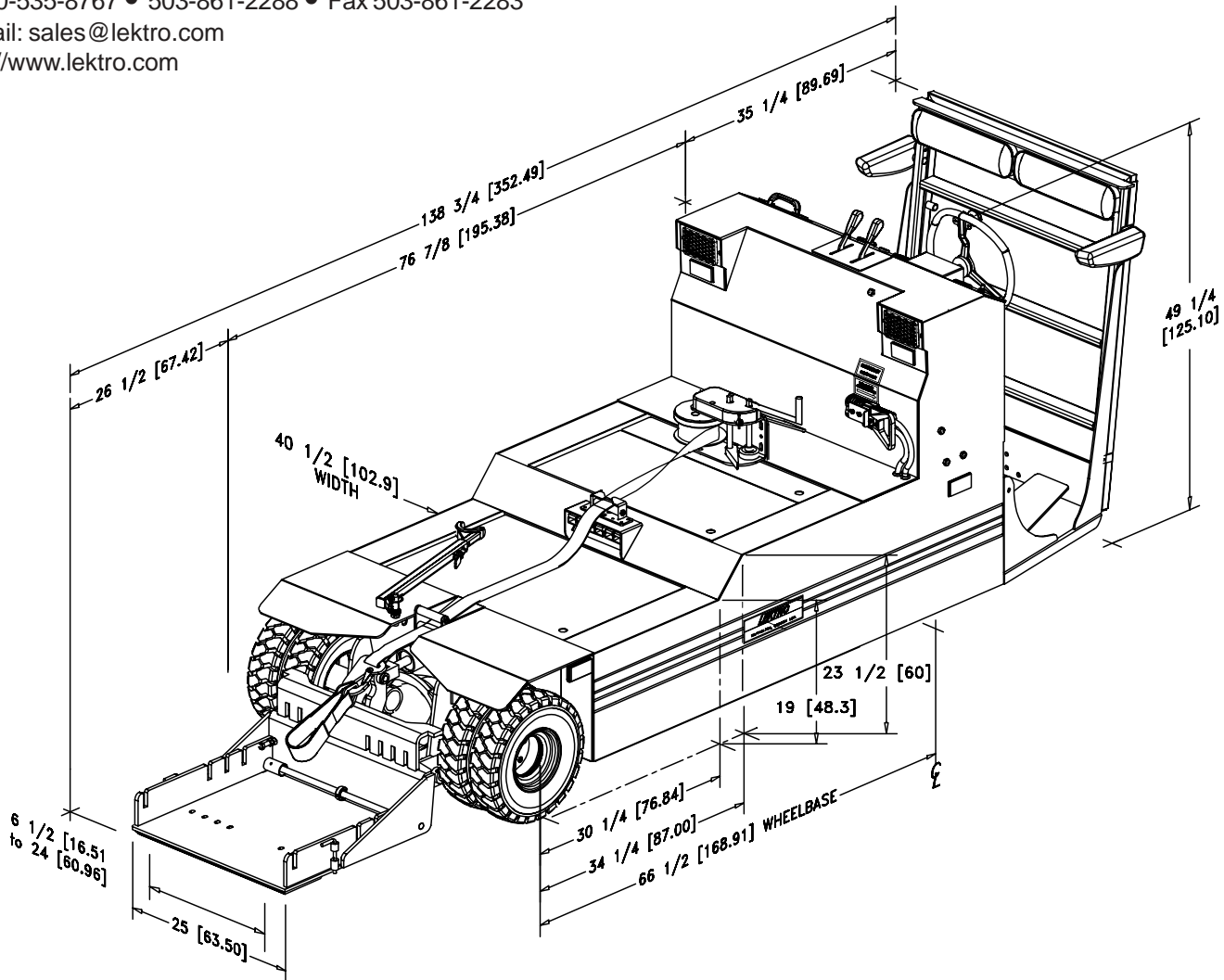

AP8600 FEATURES:

Vehicle Drive: Heavy-duty 2.5 HP, 36-volt D.C. Traction Motor coupled by double roller chain to a heavy-duty Automotive Differential, manufactured to Lektro's specifications. 5.0 HP motor optional.

Motor Speed Control: Microprocessor-Based Speed Control operated by combination Hand Throttle/Directional Lever.

Batteries: Six 6-volt industrial, 300 ampere hour Batteries wired in series.

G.P.U.: Built-in 12/24/28 volt, 800 cold cranking ampere output capability, standard. 1175 cold cranking ampere system available.

Motive Battery Charger: Fully automatic 40 ampere, 110-volt, Single Phase Charger, standard. 230-volt, 3-Phase or 50 Hz, optional.

Nose Gear Lift Cradle: Lektro's patented Universal Nose Gear Lift Cradle is activated by an Electric/Hydraulic 24-volt pump assembly with single cylinder, and is capable of handling dual and single wheel aircraft as well as those with or without wheel fairings.

Winch: Heavy-duty 2-speed Hand Winch. Strut and Winch Straps included.

Steering: Automotive-type wheel mechanically operated through chain and sprockets to an automotive gear box resulting in very responsive steering action.

Service Brakes: Foot operated single hydraulic disc-type Service Brakes acting at differential pinion shaft.

Parking Brake: Foot operated mechanical / hydraulic activated Automatic Parking Brake.

Front Drive Tires: Dual 4.80/4.00 x 8 6-ply Pneumatic Traction Drive Tires. Chains optional for slippery conditions. Poly-foam filled tires available.

Rear Steer Tires: Dual 4.80/4.00 x 8 6-ply Pneumatic Steer Tires. Poly-foam filled tires available. Steer Axle suspension, optional.

Lighting: Dual Forward and Aft Headlights, independently activated. Seven flashing amber Running Lights positioned around tug to illuminate sides, top and rear.

Extension Ladder: Four-step Ladder attached to operator's back rest.

Operator's Compartment: Two person configuration, stand-up operation with restraint.

Construction: Welded steel plate and polymers preserved by primer and automotive high-gloss red enamel paint. A special protective coating applied to decks, fenders, side and battery compartments to prevent rust, scratches and corrosion as well as custom colors are optional.

SPECIFICATIONS:

Length	138.75 in / 352.5 cm
Width	40.5 in / 103 cm
Height (at lowest steering tilt setting)	49.25 in / 125.1 cm
Turning Radius	115.5 in / 293 cm
Wheel Base	66.5 in / 168.9 cm
Vehicle Speed, Empty	7 mph / 11.2 kph
Vehicle Speed, Loaded	3 mph / 4.8 kph
**Lift Cradle Capacity	2800 lbs / 1270 kg
Nose Gear Cradle Lifting Height	9 in / 23 cm
Ground Clearance	3.5 in / 9 cm
Chassis Weight w/ Batteries & Charger	2650 lbs / 1202 kg

**Lift Capacity is calculated with 14 in / 36 cm diameter aircraft tire in lift cradle. Aircraft tire centerline at 18.5 in / 47 cm from drive tire centerline.

ADDITIONAL OPTIONS:

Limited Slip Differential, Pintle Towing Hook, Westwind Adapter, Sabreliner Adapter, MU-2 Marquise/Dauphin/S76-B Adapter, Custom Paint. Illustration may show some optional equipment.

*LEKTRO reserves the right to make changes and improvements in products and specifications without notice or obligation.
 Patent Nos. 5,151,003/5,302,075. Other Patents Pending. 04/02