

LEKTRO

1190 S.E. Flightline Drive, Warrenton, Oregon 97146-9692
 1-800-535-8767 • 503-861-2288 • Fax 503-861-2283
 E-mail: sales@lektro.com
 http://www.lektro.com

Model AP8750B AIRCRAFT TOWING VEHICLE FOR AIRCRAFT UP TO 70,000 LBS/31,752 KG

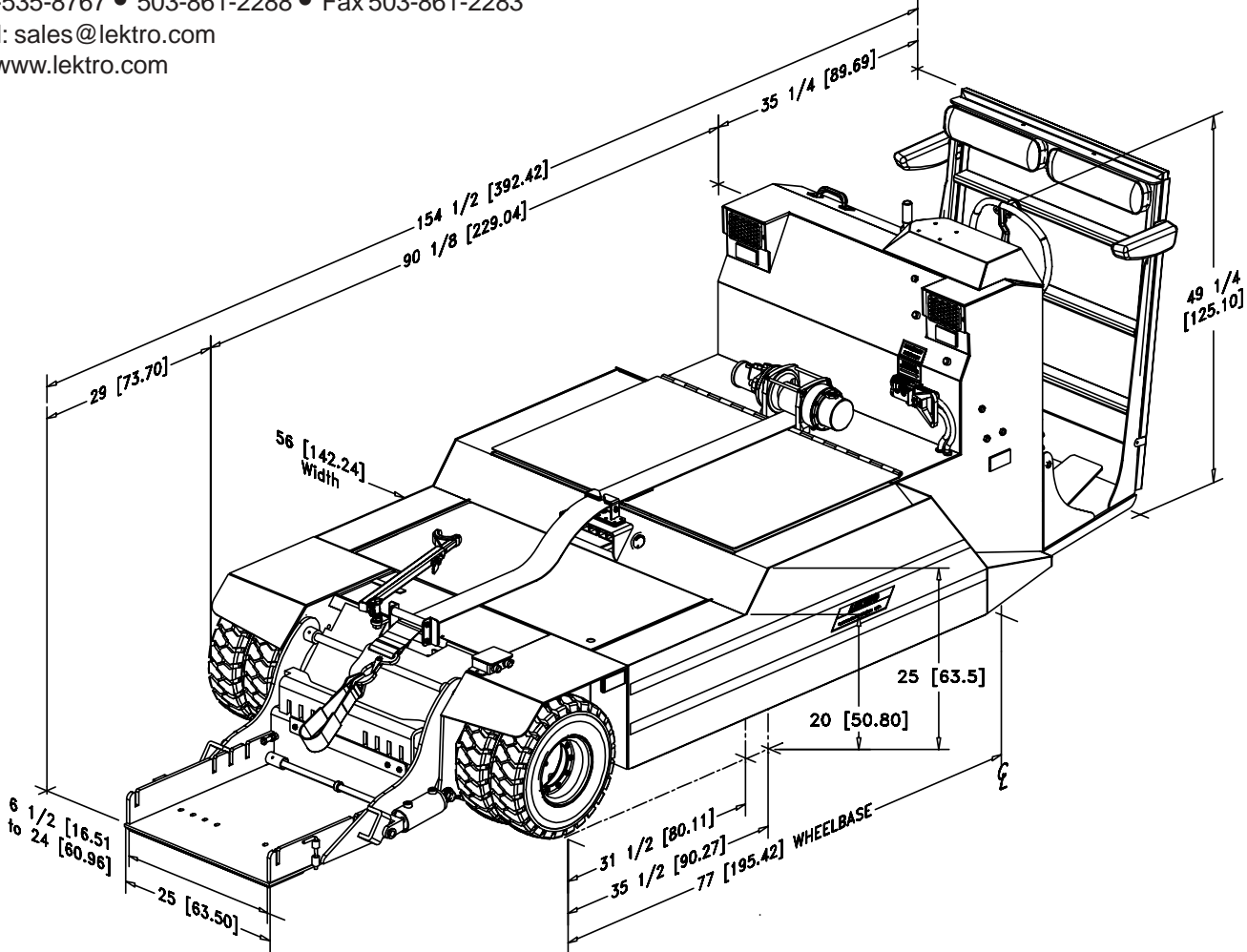

AP8750B FEATURES:

Vehicle Drive: Heavy-duty 10 HP, 48-volt D.C. Traction Motor coupled direct to drive wheels through gear drives utilizing compact design and strength to achieve maximum torque and efficiency.

Motor Speed Control: State of the art General Electric EV-100 LXT Electronic Speed Control with on-board trouble shooting diagnostics. Speed controlled by combination Hand Throttle/Directional Lever.

Batteries: Four 12-volt industrial, 300 ampere hour Batteries (6 hr. rate), wired in series. 480 ampere hour battery, optional.

G.P.U.: Built-in 12/24/28 volt, 1175 cold cranking ampere output capability with independent batteries and charging system, optional.

Battery Charger: Fully automatic 50 ampere D.C., 230-volt A.C., Single Phase Charger, standard. 3 phase or 50 hz, 100 ampere, optional.

Nose Gear Lift Cradle: Lektro's patented Universal Nose Gear Lift Cradle is activated by an Electric/Hydraulic 48-volt pump assembly with dual cylinders, and is capable of handling dual and single wheel aircraft as well as those with or without wheel fairings. A hold down provision for light-nosed aircraft is also a standard design feature.

Winch: Heavy-duty Hydraulic Winch with automatic safety cut-off. Winch Strap and universal Strut Straps included.

Steering: Automotive-type wheel mechanically operated through chain and sprockets to an automotive gear box resulting in very responsive steering action.

Service Brakes: Foot operated dual independent hydraulic disc-type Service Brakes at each drive wheel.

Parking Brake: Foot operated mechanical / hydraulic activated Automatic Parking Brake.

Front Drive Tires: Dual 5.00 x 8 8-ply Pneumatic Traction Drive Tires. Chains optional for slippery conditions. Poly-foam filled tires available.

Rear Steer Tires: Dual 5.00 x 8 8-ply Pneumatic Traction Steer Tires. Poly-foam filled tires available. Steer Axle Suspension, optional.

Lighting: Dual Forward and Aft Headlights, independently activated. Seven flashing amber Running Lights positioned around tug to illuminate sides, top and rear.

Extension Ladder: Four-step Ladder attached to operator's back rest.

Operator's Compartment: Two person configuration, stand-up operation with restraint.

Construction: Welded steel plate and polymers preserved by primer and automotive high-gloss red enamel paint. A special protective coating applied to decks, fenders, side and battery compartments to prevent rust, scratches and corrosion as well as custom colors are optional.

SPECIFICATIONS:

Length	154.5 in / 392 cm
Width	56 in / 142 cm
Height	49.25 in / 125 cm
Turning Radius	135 in / 343 cm
Wheel Base	77 in / 196 cm
Vehicle Speed, Empty	6 m.p.h. / 9.6 kph
Vehicle Speed, Loaded (To Max. Vehicle Capacity)	3.3 m.p.h. / 5.4 kph
**Lift Cradle Capacity	7000 lbs / 3175 kg
Nose Gear Cradle Lifting Height	9 in / 23 cm
Ground Clearance	5 in / 12.7 cm
Chassis Weight w/o Batteries & Charger	3080 lbs / 1397 kg
Chassis Weight w/ Motive Batteries & Charger	4480 lbs / 2032 kg
Chassis Weight w/ Motive & GPU Batteries & Charger	4980 lbs / 2259 kg

**Lift Capacity is calculated with 18 in / 46 cm diameter aircraft tire in lift cradle. Aircraft tire center line at 20.5 / 52 cm from drive tire center line.

ADDITIONAL OPTIONS:

Limited Slip Differential, Pintle Towing Hook, Specialized Aircraft Adapters: Westwind, Sabreliner, Dash 8, MU-2 Marquise/Dauphin/S76-B, Custom High-lift, Aluminum Longreach Universal Highlift. Illustration may show some optional equipment.

*LEKTRO reserves the right to make changes and improvements in products and specifications without notice or obligation.
 PATENT Nos. 5,151,003/5,302,075. Other Patents Pending. 04/03