

# LEKTRO

## Model AP8950SD AIRCRAFT TOWING VEHICLE FOR AIRCRAFT UP TO 180,000 LBS/81,647 KG

1190 S.E. Flightline Drive, Warrenton, Oregon 97146-9692  
1-800-535-8767 • 503-861-2288 • Fax 503-861-2283  
E-mail: sales@lektro.com  
http://www.lektro.com

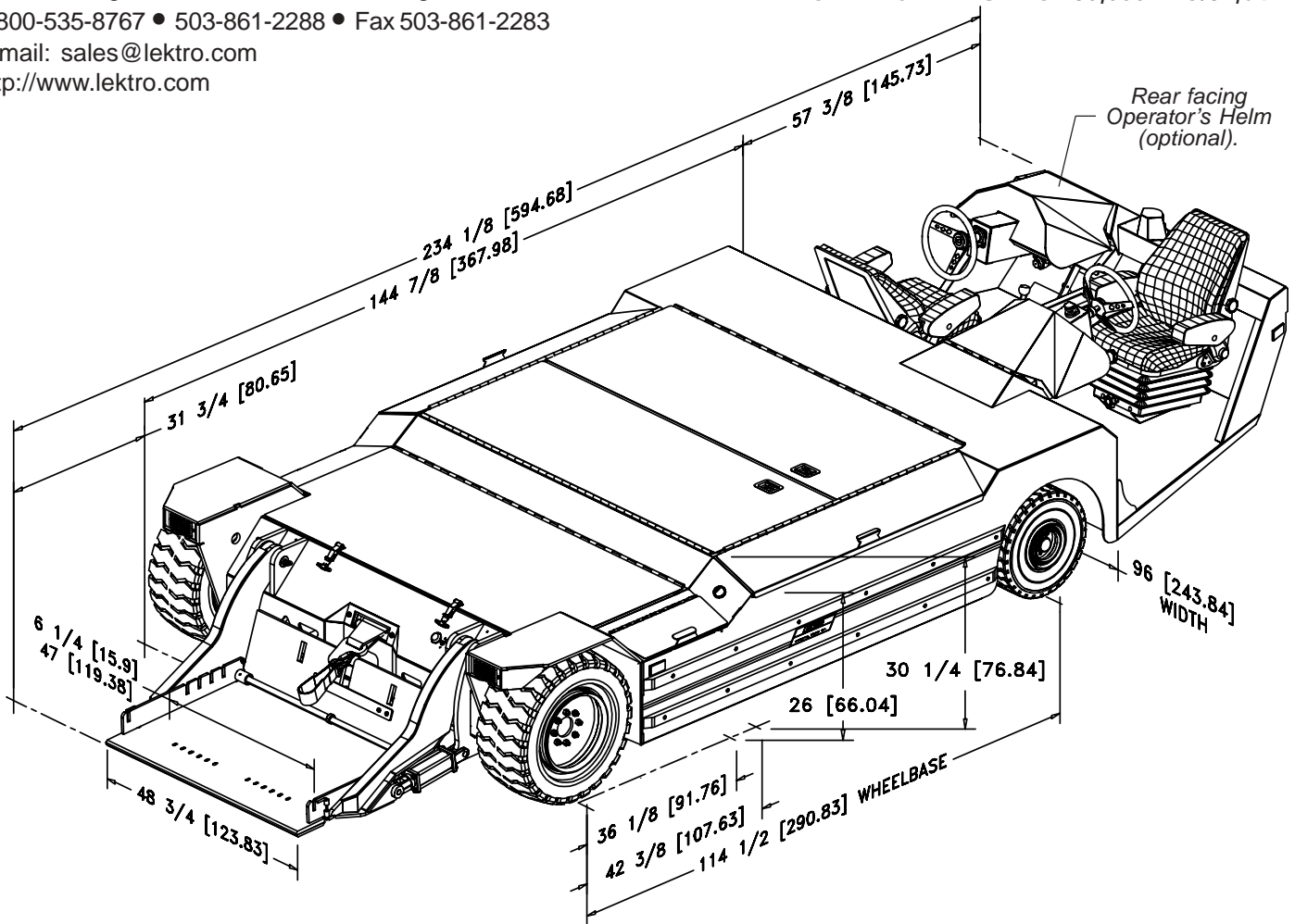

### AP8950SD FEATURES:

**Vehicle Drive:** Heavy-duty 13 inch frame, 72-volt D.C. Traction Motor coupled direct to drive wheels through high efficiency gearing.

**Motor Speed Control:** State of the art General Electric EV-200 Electronic Speed Control with on-board trouble shooting diagnostics. Speed controlled by Foot Throttle.

**Batteries:** Dual set of two 36-volt industrial, 680 ampere hour Batteries wired in series-parallel.

**G.P.U.:** Built-in 12/24/28 volt, 1175 cold cranking ampere output capability with independent batteries and charging system, optional.

**Motive Battery Charger:** Two fully automatic 100 ampere, 220-volt, Single Phase Chargers, standard. 3 phase or 50 hz, optional.

**Nose Gear Lift Cradle:** Lektro's patented Universal Nose Gear Lift Cradle is activated by an Electric/Hydraulic pump assembly with dual cylinders, and is capable of handling dual and single wheel aircraft as well as those with or without wheel fairings.

**Winch:** Heavy-duty Hydraulic Winch with automatic safety cut-off. Winch Strap and universal Strut Straps included.

**Steering:** Electric/Hydraulic Power Steering controlled through automotive type tilt wheel requiring minimal effort with very responsive steering action. Adjustable timer shuts down steering motor when tug is not in use, increasing battery shift life. Rearward facing operator's helm, optional.

**Service Brakes:** Foot operated quad independent hydraulic disc-type Service Brakes utilizing the final wheel drive gearing to achieve maximum braking with minimal brake pedal effort.

**Parking Brake:** Hand activated, industry standard, "yellow diamond" push/pull electric/hydraulic Parking Brake, coupled to quad auxiliary brake discs on final drive.

**Drive Tires:** Single 28 x 12-15 20 ply Semi Pneumatic Traction Drive Tires with Siping. Chains optional for slippery conditions.

**Steering Tires:** 21 x 8 x 9 Semi-Pneumatic Traction Steer Tires mounted to a fully suspended steer axle.

**Lighting:** Dual Forward and dual Aft Headlights, independently activated. Four flashing amber Running Lights positioned around tug to illuminate sides and top. Amber Strobe Light mounted center rear.

**Seating:** Operator and passenger seating, forward facing, constructed of industrial grade, weather resistant materials including armrests and seat belt. Operator's seat features a fully suspended, adjustable setting for height, for/aft and weight. Rear facing passenger/operator's helm, optional. Operator's cab with heater, defroster, and windshield wipers, optional.

**Construction:** Welded steel plate and polymers preserved by primer and automotive high-gloss red enamel paint. A special protective coating applied to decks, fenders, side and battery compartments to prevent rust, scratches and corrosion as well as custom colors are optional.

### SPECIFICATIONS:

Length .....	234 in / 595 cm
Width .....	96 in / 244 cm
Height (At lowest steering tilt setting) .....	37 in / 94 cm
Turning Radius .....	209 in / 531 cm
Wheel Base .....	114.5 in / 291 cm
Vehicle Speed, Empty .....	7.5 m.p.h. / 12 kph
Vehicle Speed, Loaded (To Max. Vehicle Capacity) .....	4 m.p.h. / 6.44 kph
**Lift Cradle Capacity .....	18,000 lbs / 8165 kg
Nose Gear Cradle Lifting Height .....	11 in / 28 cm
Ground Clearance .....	5 in / 12.7 cm
Chassis Weight w/o Batteries & Charger .....	8040 lbs / 3647 kg
Chassis Weight w/ Motive Batteries & Charger .....	17,000 lbs / 7711 kg
Chassis Weight w/o Motive & GPU Batteries & Charger .....	17,430 lbs / 7906 kg

\*\*Lift Capacity is calculated with 30 in / 76.2 cm diameter aircraft tire in lift cradle. Aircraft tire center line at 26 in / 66 cm from drive tire center line.

### ADDITIONAL OPTIONS:

Aircraft Towing Adapters and Highlift Adapters are available. Refer to Adapter Specifications and / or Consult Lektro customer service for specific Aircraft Adapters. Pintle Towing Hook. Illustration may show some optional equipment.

\*LEKTRO reserves the right to make changes and improvements in products and specifications without notice or obligation.

PATENT Nos. 5,261,778/5,302,075. Other Patents Pending.